

ENEE 381 First Examination
March 11, 2004, 11:00 - 12:15pm
ANSWER 3 QUESTIONS

If more than 3 are answered, best 3 will count

(1) A linearly polarized plane electromagnetic wave propagating in the z -direction in a lossless material has a magnetic field that can be represented as

$$H_x = H_0 \sin(\omega t - kz).$$

Use $\text{curl}\mathbf{H} = \mathbf{j} + \partial\mathbf{D}/\partial t$ to find the electric field of this wave. Show that the ratio

$$\frac{E_y}{H_x} = -\sqrt{\frac{\mu_0\mu_r}{\epsilon_0\epsilon_r}} = -Z. \quad (4\text{pts.})$$

What is the average Poynting vector of the wave? (2pts.) If the wave has amplitude $H_0=10\text{A/m}$ and is propagating through a material with $\epsilon_r=2$, $\mu_r=10$, what is the electric field amplitude? (1pt.)

If the electric field and magnetic field happened to be of the form

$$E_y = 10 \cos(\omega t - kz + \pi/7)$$

and

$$H_x = \frac{10}{Z} \cos(\omega t - kz - \pi/5)$$

What would be the value of the average Poynting vector? (3pts.)

(2) Calculate the total energy flux W (Watts) into a closed volume V by using

$$W = -\oint (\mathbf{E} \times \mathbf{H}) \cdot d\mathbf{S}.$$

Use the vector identity

$$\text{div}(\mathbf{E} \times \mathbf{H}) = \mathbf{H} \cdot \text{curl}\mathbf{E} - \mathbf{E} \cdot \text{curl}\mathbf{H}$$

to show where the energy flowing into the volume goes in terms of stored energy and ohmic dissipation. (5pts.)

A circular wire of radius 10mm and conductivity $5 \times 10^7 \text{ S/m}$ has a low frequency voltage applied to it that gives a field in the wire of 2V/m. Show that the ohmic dissipation per unit length in the wire is equal to the Poynting vector flux into unit length of the cylindrical surface of the wire. (5pts.)

(3) Use Maxwell's equations to show that when a plane electromagnetic traveling in the $+z$ -direction and with its electric field in the x -direction enters a lossy material with $\epsilon_r = \epsilon' - j\epsilon''$ filling the space $z > 0$ that for $z > 0$ the electric field obeys

$$\frac{\partial^2 E_x}{\partial z^2} = \mu_0\mu_r\sigma \frac{\partial E_x}{\partial t} + \epsilon_0\epsilon_r\mu_0\mu_r \frac{\partial^2 E_x}{\partial t^2}. \quad (3\text{pts.})$$

Prove that the electric field now behaves as

$$E_x = E_0 e^{j(\omega t - k'z)} e^{-\alpha z}. \quad (2\text{pts.})$$

Derive equations for k' and α in terms of the frequency and dielectric properties of the material. (2pts.)

If $\epsilon_r = 4 - j0.01$, what is the $1/e$ penetration distance of the wave into the lossy material? (3pts.)

(4) A plane electromagnetic wave with magnetic field $H_y = H_i e^{j(\omega t - kz)}$ traveling in free space is incident on a perfect conductor lying in the plane $z = 0$. Derive equations that show the real total electric and magnetic fields for $z \leq 0$. (6pts.) If the magnetic field of the incident wave is 1A/m, what is the surface current in the conductor? (3 pts.) Explain which way the force on the conductor acts because of the magnetic field and surface current? (1 pt.)

$$\epsilon_0 = 8.854 \times 10^{-12} \text{ F/m.}$$

$$\mu_0 = 4\pi \times 10^{-7} \text{ Henry/m.}$$

$$c_0 = 2.998 \times 10^8 \text{ m/s.}$$

Maxwell's equations

$$\text{curl}\mathbf{E} = -\frac{\partial\mathbf{B}}{\partial t}.$$

$$\text{curl}\mathbf{H} = \mathbf{j} + \frac{\partial\mathbf{D}}{\partial t}.$$

$$\text{div}\mathbf{D} = \rho.$$

$$\text{div}\mathbf{B} = 0.$$

$$k = \omega\sqrt{\epsilon_0\epsilon_r\mu_0\mu_r}.$$

$$k = \omega/c.$$

$$\text{curl curl}\mathbf{E} = \text{grad div}\mathbf{E} - \nabla^2\mathbf{E}.$$

$$Z_0 = \sqrt{\mu_0/\epsilon_0} = 376.7 \text{ ohm.}$$

$$\mathbf{D} = \epsilon_0\mathbf{E} + \mathbf{P}.$$

$$\text{Curl}\mathbf{E} = \left(\frac{\partial E_z}{\partial y} - \frac{\partial E_y}{\partial z}\right)\hat{\mathbf{i}} + \left(\frac{\partial E_x}{\partial z} - \frac{\partial E_z}{\partial x}\right)\hat{\mathbf{j}} + \left(\frac{\partial E_y}{\partial x} - \frac{\partial E_x}{\partial y}\right)\hat{\mathbf{k}}.$$

ENEE 381 Second Examination

April 29, 2004, 11:00 - 12:15pm

ANSWER 3 QUESTIONS

If more than 3 are answered, best 3 will count

- (1) On a generalized transmission line with series impedance Z and shunt admittance Y the propagation constant γ of a wave on the line is

$$\gamma = \sqrt{ZY}$$

For the generalized line shown below calculate the wave propagation β in the pass band(s) and the attenuation constant α in the stop band(s). (4pts.) Plot the $\omega - \beta$ and $\omega - \alpha$ diagrams.(4pts.) On the graphs show the asymptotic behavior for $\omega \rightarrow \infty$, $\omega \rightarrow$ cutoff frequency or frequencies, and as $\omega \rightarrow 0$. On the graph for a selected frequency indicate how phase and group velocity are determined. (2pts.)

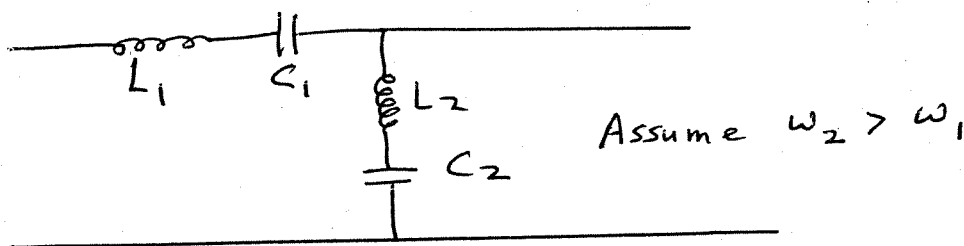

- (2) A transmission line of characteristic impedance 50 ohm is terminated with a load Z_L . At 0.15λ from the load the line can be matched with a shorted 50 ohm stub 0.12λ long connected in parallel to the main line as shown below. What is the value of the load? (6pts.) What are the values of ρ , ϕ , and the standing wave ratio S if the stub is removed? (3pts.) If an open stub were used for matching how long would it be? (1pt.)

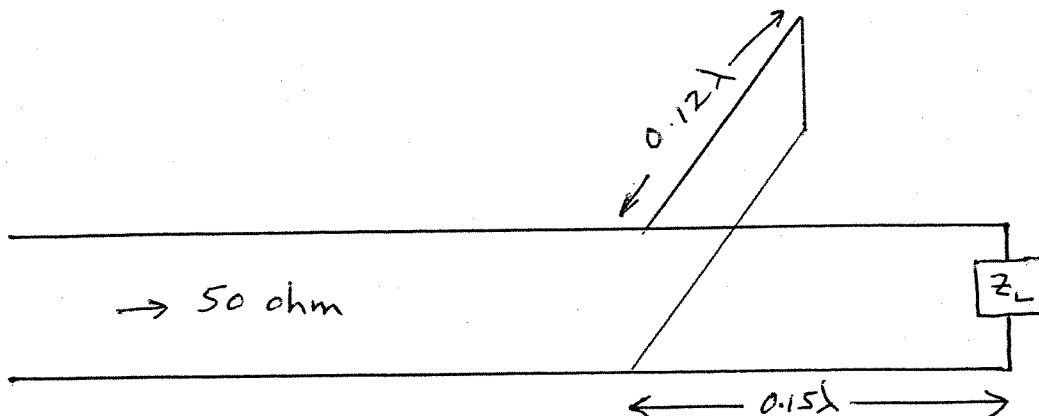

(3) A low loss transmission line can be represented as shown below.

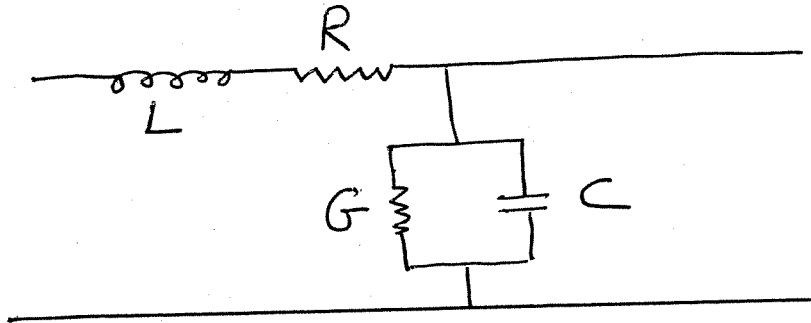

A voltage wave traveling along the line can be represented as

$$V(z, t) = V_0 e^{j(\omega t - kz)} e^{-\alpha z}$$

Prove that the attenuation coefficient α can be written as

$$\alpha = \frac{W_L}{2W_T}$$

where W_L is the power loss with distance on the line, and W_T is the power being transported along the line.

Derive an expression for the value of α in terms of R and G . What is the value of α if $Z_0 = 75 \text{ ohm}$, $\omega = 2\pi \times 10^8 \text{ rad/s}$, $L = 20 \text{ nanohenry/m}$, and the phase velocity on the line is $v_p = 2 \times 10^8 \text{ m/s}$.

$$R = 10^{-3} \quad G = 10^{-6} \text{ S/m}$$

Hint: $Z_0 = \sqrt{L/C}$, $(1+x)^n \simeq 1+nx$ for $x \ll 1$.

(4) A plane electromagnetic wave in the TE configuration with electric field $E_i = E_y = E_0 e^{j(\omega t - ks)}$ traveling in free space is incident on a perfect conductor lying in the plane $z = 0$ at angle of incidence θ . Derive equations that show the real total electric and magnetic fields for $z \leq 0$. (8pts.) Show that there is a node of the electric field node at distance $\lambda/(2 \cos(\theta))$ from the surface. (2pts.)

$$\epsilon_0 = 8.854 \times 10^{-12} \text{ F/m.}$$

$$\mu_0 = 4\pi \times 10^{-7} \text{ Henry/m.}$$

$$c_0 = 2.998 \times 10^8 \text{ m/s.}$$

For a medium $E_x/H_y = Z$.

ENEE 381 Final Examination
May 13, 2004, 8:00 - 10:00am
ANSWER 4 QUESTIONS

If more than 4 are answered, best 4 will count

(1) Starting from Maxwell's equations show that the displacement vector and flux density in free space satisfy the 3-D wave equation. (3pts.) Prove also that the ratio of the displacement vector to flux density amplitudes of a linearly polarized wave obeys (2pts.)

$$\frac{D_x}{B_y} = -\frac{D_y}{B_x} = \sqrt{\frac{\epsilon_0 \epsilon_r}{\mu_0 \mu_r}}$$

A plane wave has $D_x = 100\epsilon_0 \cos(3\pi 10^7 t - kz)$ and is traveling in a medium with $\epsilon_r = 9$. What are the electric field amplitude, wavelength, propagation constant, impedance and magnetic field of the wave? (3pts.) If the plane wave in this medium had $D_x = 900\epsilon_0 \cos(3\pi 10^7 t - kz - \pi/4)$, $B_y = D_x Z_0 \sin(3\pi 10^7 t - kz - \pi/4)$, what would be the average Poynting vector? (1pt.) In what situations is the Poynting vector zero? (1pt.)

(2) Prove that the input impedance at point $z = -\ell$ on a transmission line of characteristic impedance Z_0 terminated at $z = 0$ with a load Z_L is (6 pts.)

$$Z_i = Z_0 \left[\frac{Z_L \cos(k\ell) + j Z_0 \sin(k\ell)}{Z_0 \cos(k\ell) + j Z_L \sin(k\ell)} \right]$$

Use this result to prove that a transmission line of characteristic impedance Z_1 can be matched to a second line of characteristic impedance Z_3 with an intermediate section of line of characteristic impedance Z_2 where $Z_2 = \sqrt{Z_1 Z_3}$. (3pts.) What length is needed for the intermediate line? (1pts.)

(3) A TM wave is incident on a dielectric boundary at angle θ_1 . Prove that the angle of reflection equals the angle of incidence and that the angle of refraction obeys Snell's Law. (4pts.) Prove that the reflection and transmission coefficients satisfy $\rho + \tau = 1$. (2pts.)

A TM wave of intensity 1W/m^2 strikes a boundary between 2 lossless dielectrics with $\epsilon_{r1} = 4$, $\epsilon_{r2} = 9$, at an angle of 45° . What is the intensity of the transmitted wave? (3pts.) Where is the nearest magnetic field minimum to the boundary that is not at the boundary? (1pt.)

Hint: for TM waves $Z' = Z \cos(\theta)$.

(4) A 50ohm transmission line is being operated at a frequency of 10GHz. The phase velocity on the line is $2 \times 10^8 \text{m/s}$. The line is found to be matched at a distance 0.12λ from the load with an open 50ohm stub 4.2λ long connected in shunt (parallel) with the main line. What is the load (5pts.) Without the stub what are $|\rho|$, ϕ , and the VSWR? (2pts.) What kind of stub could be used to match the line that would have the shortest length. (1pts.) What is this actual length in meters? (1pt.) Where could you match the line with a capacitor in series with the main line? (1pt.) USE THE SMITH CHART.

(5) Prove that the cutoff frequency of a TM mode in a rectangular waveguide of dimension $a \times b$ is (5pts.)

$$\nu_c = \frac{c}{2} \sqrt{\left(\frac{m}{a}\right)^2 + \left(\frac{n}{b}\right)^2}$$

Hint:

$$\frac{\partial^2 E_z}{\partial x^2} + \frac{\partial^2 E_z}{\partial y^2} = -(\gamma^2 + k^2)E_z.$$

For $\nu=10\text{GHz}$, $a=50\text{mm}$, $b=20\text{mm}$, and a TM_{11} mode what are the values of β , λ_g , v_p , and v_g ? (3pts.)

Sketch the $\omega - \beta$ behavior above ω_c and $\omega - \alpha$ below ω_c . (2pts.)

(6) A TE_{12} mode is propagating at frequency 20GHz in a waveguide with $a=100\text{mm}$, $b=50\text{mm}$. The wave enters a second part of the waveguide that is filled with a lossless dielectric of $\epsilon_r=2$. What are $|\rho|$, ϕ and the VSWR? (8pts.) Where is the nearest magnetic field maximum to the boundary? (2pts.)

Hint: information given in question (5) should be helpful. Also:

$$Z_{TE} = \frac{Z_0}{\sqrt{1 - (\omega_c/\omega)^2}}$$

$$\epsilon_0 = 8.854 \times 10^{-12} \text{ F/m.}$$

$$\mu_0 = 4\pi \times 10^{-7} \text{ Henry/m.}$$

$$c_0 = 2.998 \times 10^8 \text{ m/s.}$$

$$Z_0 = \sqrt{\mu_0/\epsilon_0} = 376.7 \text{ ohm.}$$

$$\epsilon'' = \sigma/\omega\epsilon_0.$$

Maxwell's equations

$$\text{curl}\mathbf{E} = -\frac{\partial\mathbf{B}}{\partial t}.$$

$$\text{curl}\mathbf{H} = \mathbf{j} + \frac{\partial\mathbf{D}}{\partial t}.$$

$$\text{div}\mathbf{D} = \rho.$$

$$\text{div}\mathbf{B} = 0.$$

$$k = \omega\sqrt{\epsilon_0\epsilon_r\mu_0\mu_r}.$$

$$k = \omega/c.$$

$$\text{curl curl}\mathbf{E} = \text{grad div}\mathbf{E} - \nabla^2\mathbf{E}.$$

$$Z_0 = \sqrt{\mu_0/\epsilon_0} = 376.7 \text{ ohm.}$$

$$\mathbf{D} = \epsilon_0\mathbf{E} + \mathbf{P}.$$

$$\text{Curl}\mathbf{E} = \left(\frac{\partial E_z}{\partial y} - \frac{\partial E_y}{\partial z}\right)\hat{\mathbf{i}} + \left(\frac{\partial E_x}{\partial z} - \frac{\partial E_z}{\partial x}\right)\hat{\mathbf{j}} + \left(\frac{\partial E_y}{\partial x} - \frac{\partial E_x}{\partial y}\right)\hat{\mathbf{k}}.$$